

MOUNTING PROCEDURES

1. Extend forks 8". Approach truck from rear with forks centered on truck. Raise forks 2" above fork rest on mount. Check integrity of mount and transport daily.

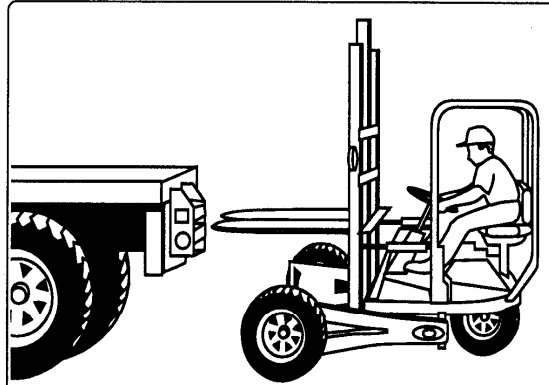

2. Drive into mount until mast hits stops. Put Donkey in neutral.

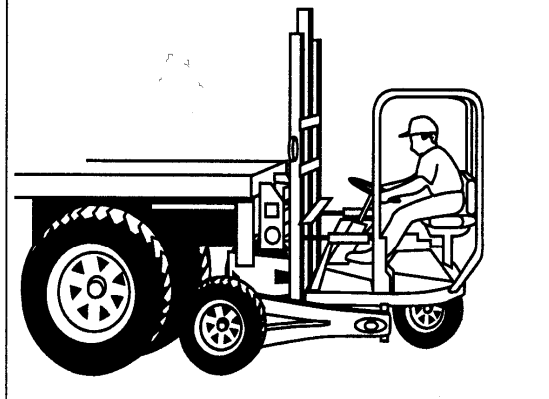

3. Push carriage lever down to lift Donkey one foot off ground. Pull mast tilt lever back to fully shorten tilt cylinders. Do not apply brakes. Push carriage lever down again until Donkey is raised so the tubular mast cross member is 2" above mounting pockets.



MOUNTING

continued

4. Pull fork extend lever back to pull Donkey forward until it stops. Pull carriage lever up to set Donkey down into pockets.

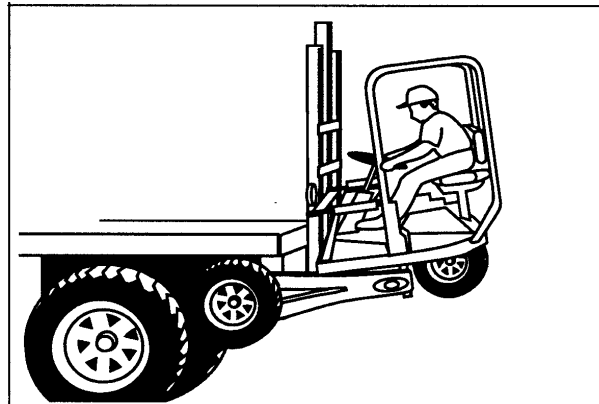

5. **IMPORTANT!** Turn off engine. **With engine off**, push all levers down and then pull all levers up until all movement stops. This releases pressure in the hydraulic system.

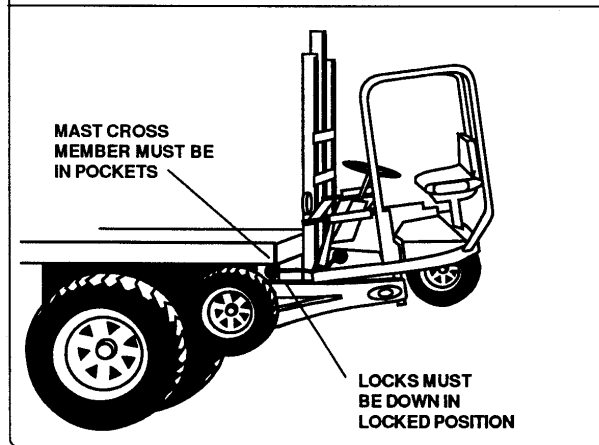

6. Dismount and inspect to see that the tubular mast cross member is in **BOTH** pockets and that **BOTH** locks are in the down and locked position.

7. Attach Safety Chain to Chain Lock. Attach truck taillight connector to Donkey. Verify that Donkey lights are working.

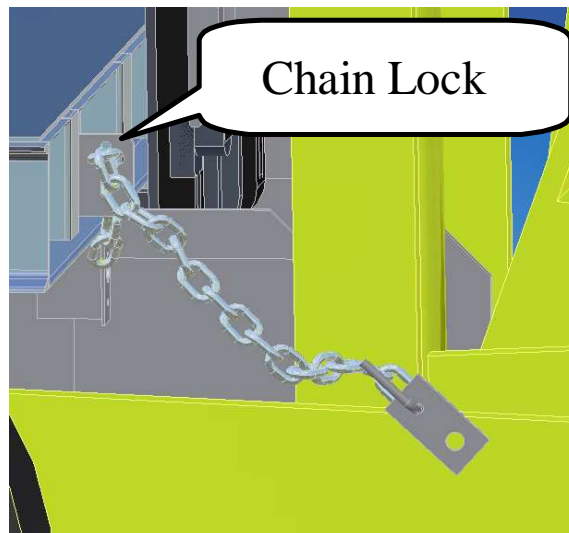

MOUNTING

continued

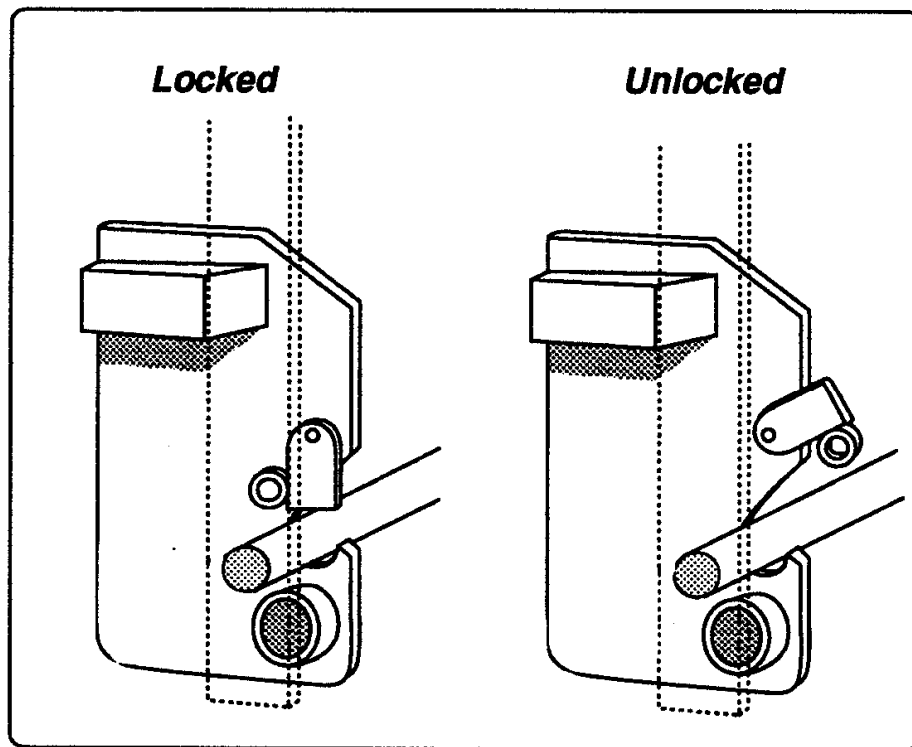

ALWAYS DOUBLE CHECK THAT THE DONKEY IS LOCKED in the mounting brackets before transporting.

When the Donkey has been left unattended on the truck, check the locks before transporting.

Move to unlocked position prior to dismounting Donkey from the truck.

CHECK INTEGRITY OF MOUNT AND TRANSPORT FRAME DAILY. Inspect for cracks in frame or welds.

DISMOUNTING

1. Detach taillight connector.

Disconnect safety chains from truck. Raise locks. Start engine. Climb into driver's seat. Fasten seat belt.



2. Pull mast tilt lever **BACK** to tip front tires down. **Do not move lever forward with engine running.** Damage to cylinders and/or Donkey could result.

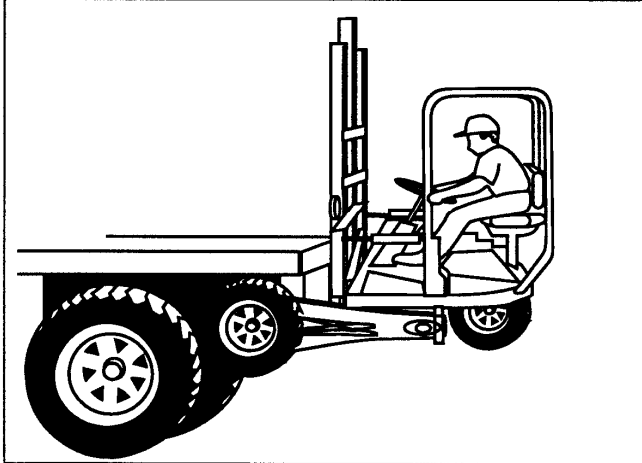

3. Push carriage lever down to lift Donkey 2".

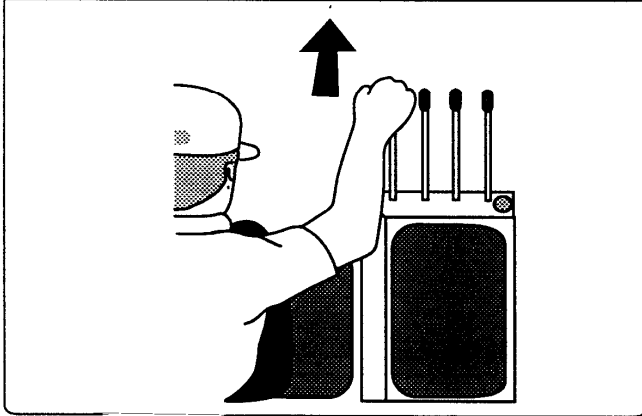

DISMOUNTING

continued

4. Do not apply brakes. Push fork extend lever down to move Donkey back 4”.

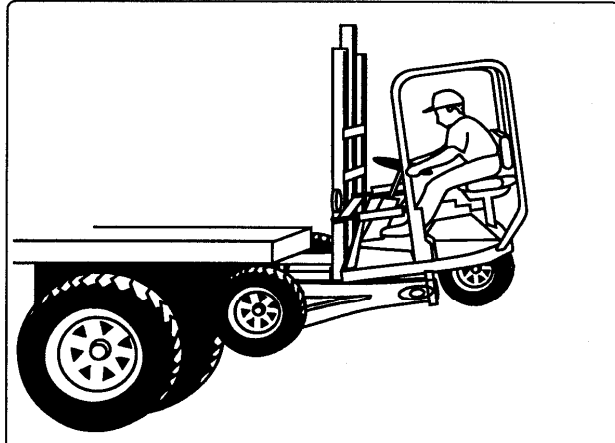

5. Pull carriage lever up to lower Donkey to the ground. Push mast tilt lever down to level Donkey.

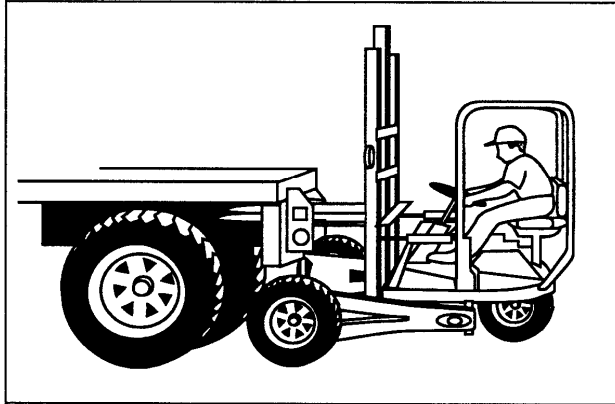

6. Pull carriage lever up until forks are off crossmember.

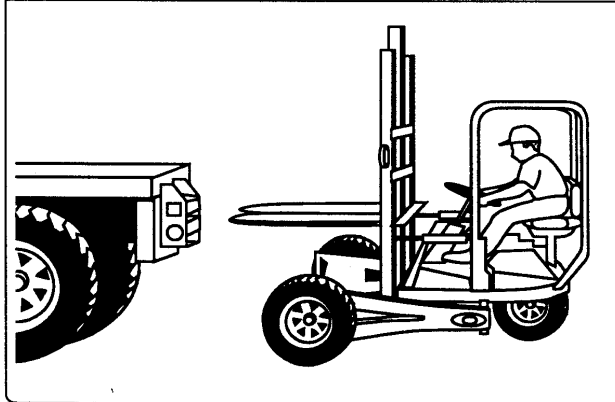

Put Donkey in reverse and back away from truck.